



Alpha Continuity: 1000/ 2000/ 3000

Indoor Double Conversion Online UPS User Manual

Part # 0170009-J0
Effective: 06/2012



Alpha Continuity: 1000/2000/3000 Indoor Double Conversion Online UPS

 **NOTE:**

Photographs contained in this manual are for illustrative purposes only. These photographs may not match your installation.

 **NOTE:**

Operator is cautioned to review the drawings and illustrations contained in this manual before proceeding. If there are questions regarding the safe operation of this powering system, contact Alpha Technologies or your nearest Alpha representative.

 **NOTE:**

Alpha shall not be held liable for any damage or injury involving its enclosures, power supplies, generators, batteries, or other hardware if used or operated in any manner or subject to any condition inconsistent with its intended purpose, or if installed or operated in an unapproved manner, or improperly maintained.

Copyright

Copyright © 2012 Alpha Technologies Ltd. All rights reserved. Alpha is a registered trademark of Alpha Technologies.

No part of this documentation shall be reproduced, stored in a retrieval system, translated, transcribed, or transmitted in any form or by any means manual, electric, electronic, electromechanical, chemical, optical, or otherwise without prior explicit written permission from Alpha Technologies.

This document, the software it describes, and the information and know-how they contain constitute the proprietary, confidential and valuable trade secret information of Alpha Technologies, and may not be used for any unauthorized purpose, or disclosed to others without the prior written permission of Alpha Technologies.

The material contained in this document is for information only and is subject to change without notice. While reasonable efforts have been made in the preparation of this document to assure its accuracy, Alpha Technologies assumes no liability resulting from errors or omissions in this document, or from the use of the information contained herein. Alpha Technologies reserves the right to make changes in the product design without reservation and without notification to its users.

Table of Contents

1. Important Safety Instructions	4
1.1 Important Information	4
1.2 Storage Instructions	4
2. Introduction	5
2.1 General Characteristics.....	5
2.2 Special Features	5
3. Preparation for Installation	6
3.1 Inspection.....	6
3.2 Storage.....	6
3.3 Unpacking	6
3.4 Selecting an Installation Location.....	7
3.5 UPS Position	8
3.6 UPS Front Panel	12
3.7 Rear Panel	13
3.8 Communication Ports.....	15
4. Installation.....	16
4.1 Connecting Utility and Load	16
4.2 Connecting the Computer Interface Port.....	17
4.3 Operating Modes and Voltage System Configuration	17
4.4 REPO Switch	20
5. Operation	21
5.1 Front Panel LCD	21
5.2 Start Up from the LCD Panel	22
6. UPS Maintenance	29
6.1 Battery Replacement Precautions.....	29
6.2 Battery Replacement.....	29
6.3 Troubleshooting.....	32
7. Optional Communication Cards	35
7.1 R2E (2nd RS-232) card.....	35

7.2	USB card.....	35
7.3	DCE (Dry Contact) card	35
7.4	SNMP Cards	35
8.	Specifications.....	36
9.	Warranty and Service Information	40

1. Important Safety Instructions

1.1 Important Information

SAVE THESE INSTRUCTIONS – This manual contains important Instructions that must be followed during the installation and maintenance of the UPS.

- The UPS has its own internal energy source (battery). A voltage may be present at the output terminals even when no AC input power is available.
- This UPS is equipped with an EMI filter. To prevent potential leakage current hazard, ensure that the AC main supply is securely grounded.
- Make sure that the AC utility outlet is correctly grounded.
- Make sure that the input voltage to the UPS matches the rating on its name plate. Use a certified input power cable with the correct plugs and sockets for the appropriate voltage system.
- Install the UPS indoors only as it is not designed for outdoor use. Install in a temperature-controlled indoor area free of conductive contaminants
- To prevent the UPS from overheating, keep all ventilation openings unobstructed. Do not place anything on top of the UPS. Keep the UPS rear panel at least 20 cm away from the wall or other objects.
- Units are considered acceptable for use in a maximum ambient of 40°C. Make sure the UPS is installed in an appropriate environment—0 to 40°C (32 to 104°F) ambient temperature, and 30 to 90% relative humidity (non-condensing).
- Do not install the UPS in direct sunlight. Failure of the batteries under these conditions may void the warranty.
- Do not install in a inflammable or hazardous environment.
- Dusty, corrosive, or salty environments can damage the UPS.
- Install the UPS away from objects that give off excessive heat and areas that are excessively wet.
- Do not install the UPS in an environment with sparks, smoke or gas. Not for use in a computer room as defined in the Standard for the Protection of Electronic Computer/Data processing Equipment, ANSI/NFPA 75.
- The entrance of liquids or foreign objects into the UPS will void the warranty.
- The battery will gradually discharge if the system is unused for extended periods.
- If unused, recharge the UPS every 2 to 3 months. Neglecting to do so will void the warranty. The batteries charge automatically and are kept in good condition if the UPS is installed and used.
- Always switch off the UPS and disconnect the batteries before relocating the UPS. It may cause electrical shocks if the output is not completely switched off.
- Do not open the UPS—there are no serviceable parts inside. Opening the UPS will void the warranty.
- Do not repair the UPS yourself Contact your local supplier. Opening the UPS will void the warranty.

1.2 Storage Instructions

Store the UPS in a location where the temperature ranges between -15°C (+5°F) to 40°C (104°F).

For extended storage in moderate climates, charge the batteries for 12 hours every 3 months. Connect the UPS to the utility supply and switch on the input breaker located at UPS rear panel. Repeat this procedure every 2 months if the ambient storage temperature is above 30°C (86°F).

2. Introduction

2.1 General Characteristics

True double conversion online technology provides uninterrupted output to your critical device with stable, regulated, transient-free, pure sine wave AC power.

- High-efficiency pulse-width modulation (PWM) sine-wave topology yields excellent overall performance. The output is capable of handling high crest factor and high inrush current loads.
- User-friendly plug and play design allows hassle-free installation. All units up to 3kVA are supplied with input cables and output sockets as standard.
- Built-in maintenance-free sealed-type battery minimizes after-sales service.
- Automatic overload protection switches the output from inverter mode to bypass mode if the load increases to 105 to 120% of full load for 30 seconds and automatically enables inverter mode when the overload condition is removed.
- If the output is short-circuited, the UPS locks automatically, provides visual & audible alarms and cuts the output supply until the short circuit situation is resolved.
- The USB / RS232 interface provides convenient plug and play with other IT products powered by the UPS.

2.2 Special Features

- High frequency transformer-less technology with a rack/tower convertible enclosure facilitates integration of the UPS even in difficult environments with space constraints.
- This UPS is equipped with fully digitized control logic for greater functionality and an enhanced high level of protection. Digital signal processing (DSP) enhances the UPS communication capability by providing the flexibility for easy remote control and monitoring.
- Wide input voltage tolerance from 60V to 144V (120V version) or 120V to 288V (230V version) allows under-voltage or over-voltage correction without unnecessary battery drain which helps to extend the battery life span.
- DC-start function ensures start-up of the UPS even during power outages.
- Revolutionary battery management circuit analyzes battery discharging status to adjust the battery cut-off point and extend the batteries' life span.
- Active Power Factor Correction (PFC) control function constantly maintains the UPS Input Power Factor (PF) at > 0.99 for energy efficiency.
- Selectable Bypass input voltage tolerance (Sensitivity low/high) prevents the supply of under or over voltage to the loads in Bypass mode. The selectable Voltage ranges are:
 - Sensitivity Low: 90/ 180 to 130/ 260V
 - Sensitivity High: 97/ 194 to 130/ 260V
- Large number of selectable output voltages (100/ 110/ 115/ 120/ 127 V or 200/ 208 /220 /230 /240 V) meet the requirements of various voltage systems.
- The UPS complies with various stringent international standards for Electromagnetic Interference & Compatibility (EMI & EMC).

3. Preparation for Installation

Read the safety instructions on page 4 before installing the UPS.

3.1 Inspection

Inspect the UPS upon receipt. Notify the carrier and dealer if there is any damage. The packaging is recyclable; save it for reuse or dispose of it properly.

3.2 Storage

If stored at -15 to +30 °C (+5 to +86 °F), charge the UPS batteries every three months.

If stored at +30 to +40 °C (+86 to +104 °F), charge the UPS batteries every two months.

3.3 Unpacking

1. Remove the UPS from the packing materials.
2. A standard unit includes:
 - One (1) user manual.
 - One (1) AC input power cord (not supplied with hard wired models).
 - Two (2) IEC output cables (for UPS models with IEC sockets only).
 - One (1) set of UPS communication software on CD with RS232 cable.
 - The accessories shown below for tower and rack mounting:

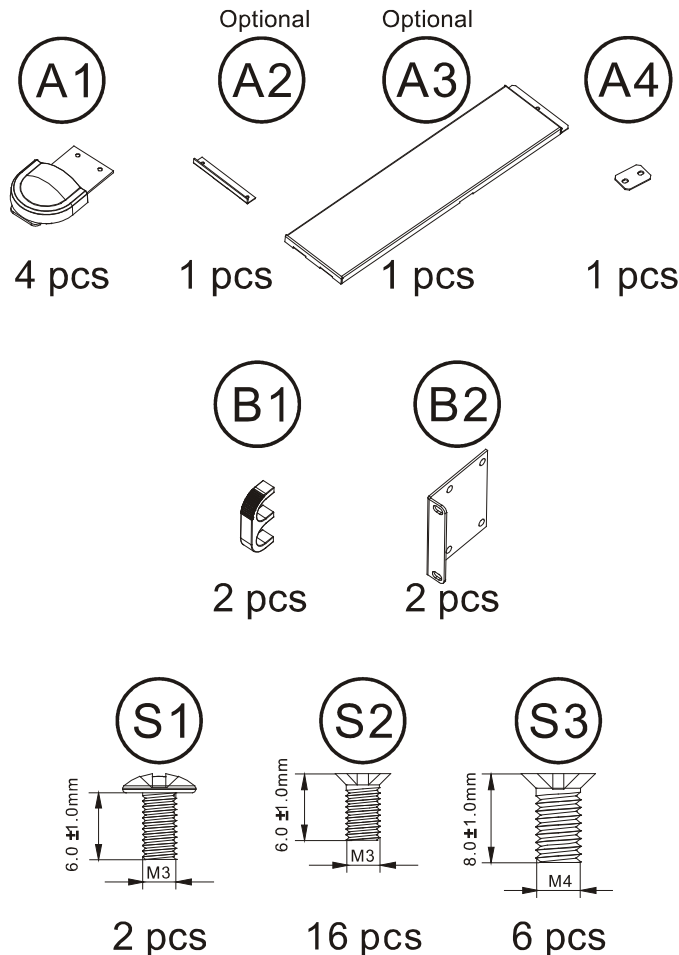

3.4 Selecting an Installation Location

The UPS contains a microprocessor, which must be installed in a well-ventilated and humidity controlled environment. Select an environment that minimizes the possibility of damage to the UPS and extends the life of the UPS. Follow the instructions below:

1. Ensure there is at least 20 cm (8 inches) of clearance between the rear panel of the UPS and the wall or other obstructions.
2. For PLUGGABLE EQUIPMENT, the socket-outlet shall be installed near the equipment and shall be easily accessible.
3. Do not block the air-flow to the ventilation openings of the unit.
4. Ensure that the environmental conditions of the installation site are within the specified temperature and humidity limits. Avoid excessive heat and moisture.
5. Do not place the UPS in a dusty or corrosive environment or near any flammable objects.
6. This UPS is not designed for outdoor use.

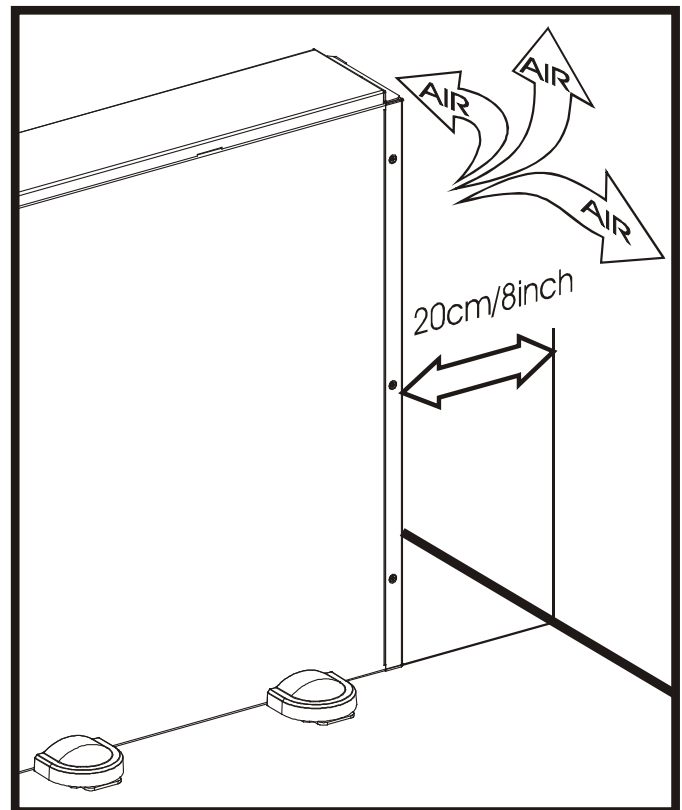
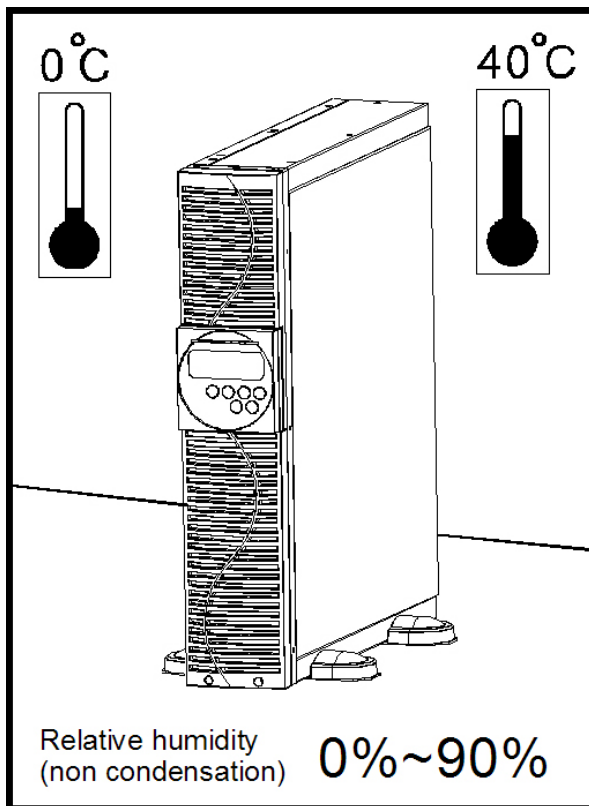

3.5 UPS Position

The UPS can be installed in two different orientations: tower mount (stand alone) or rack mount. To install the UPS as a tower, see the next section. For rack mount, see Section 3.5.3.

3.5.1 Tower Mount (Stand Alone)

Step 1

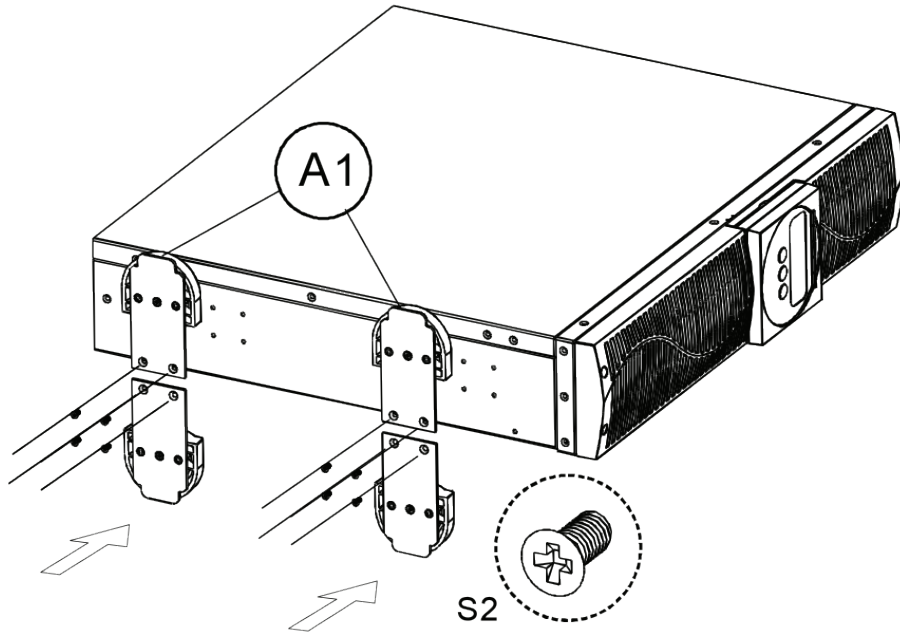

NOTE:

See Section 3.6 to rotate the LCD display to match the physical orientation of the unit.

Step 2

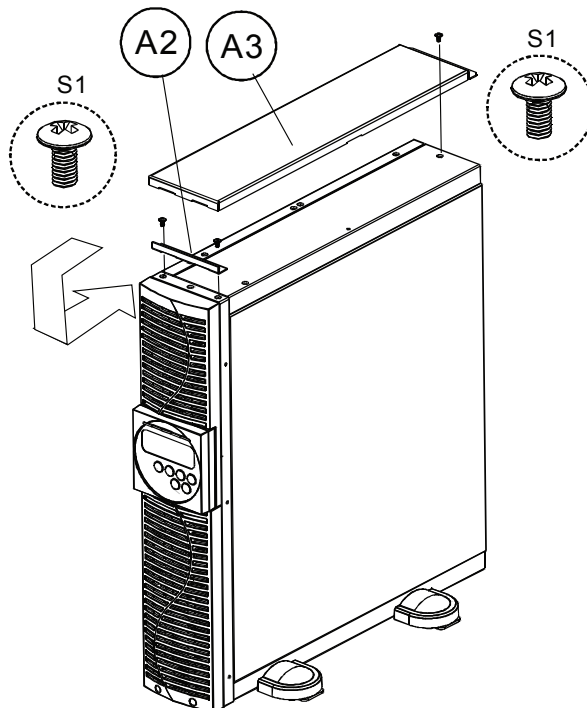

3.5.2 Power Module + Battery Module

Step 1

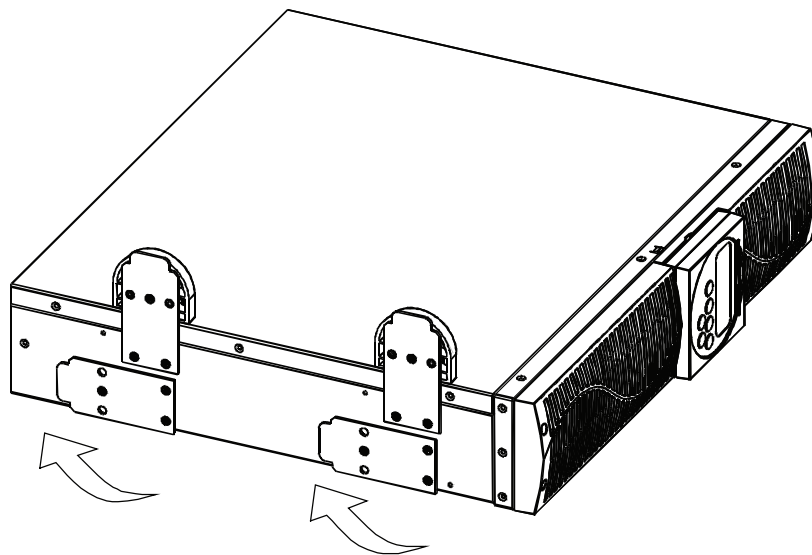

Step 2

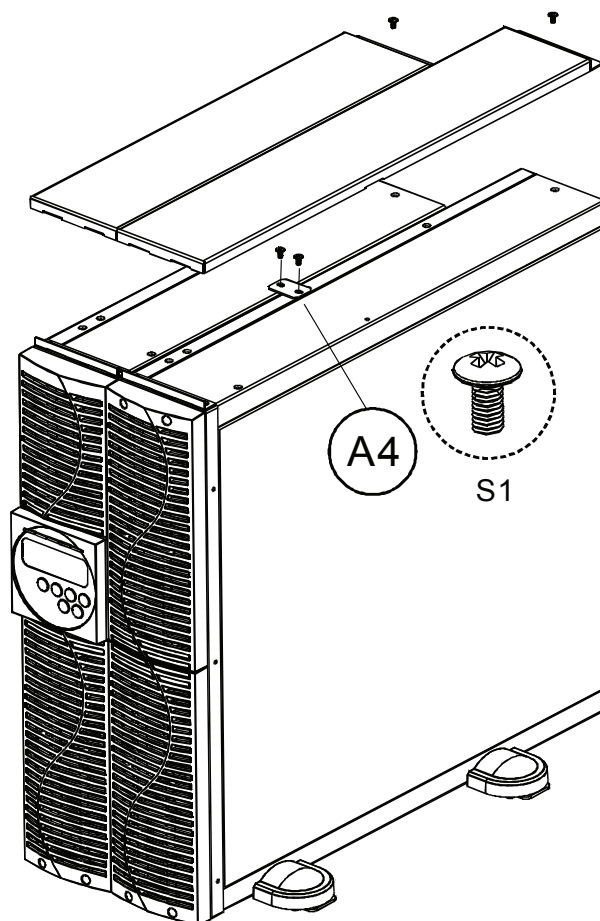

3.5.3 Rack-Mount Setup

Step 1

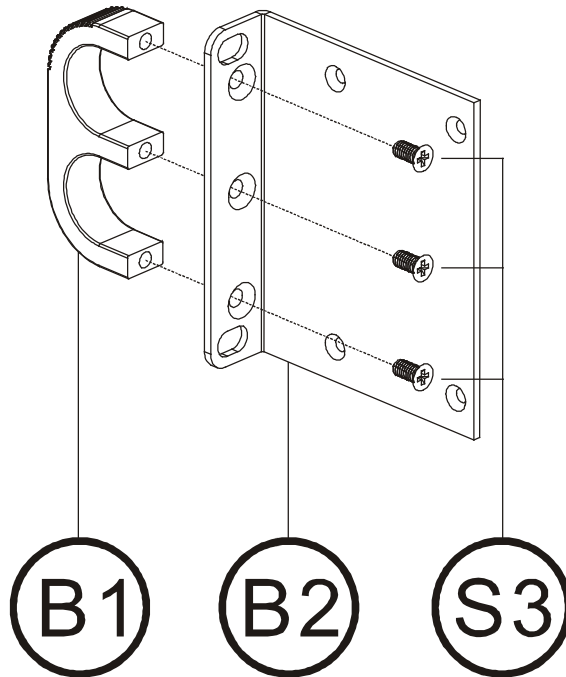

Step 2

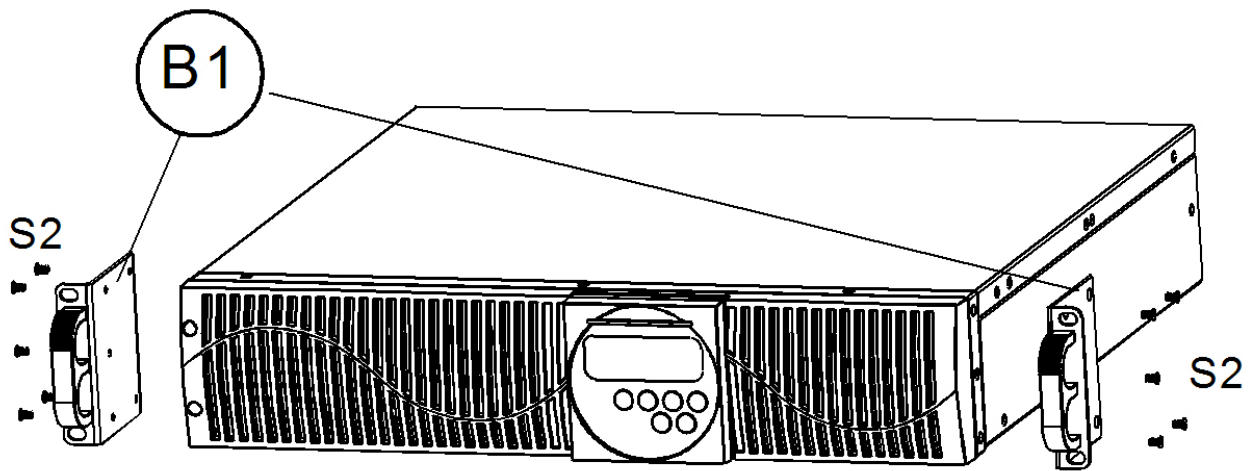

NOTE:

See Section 3.6 to rotate the LCD display to match the physical orientation of the unit.

Step 3

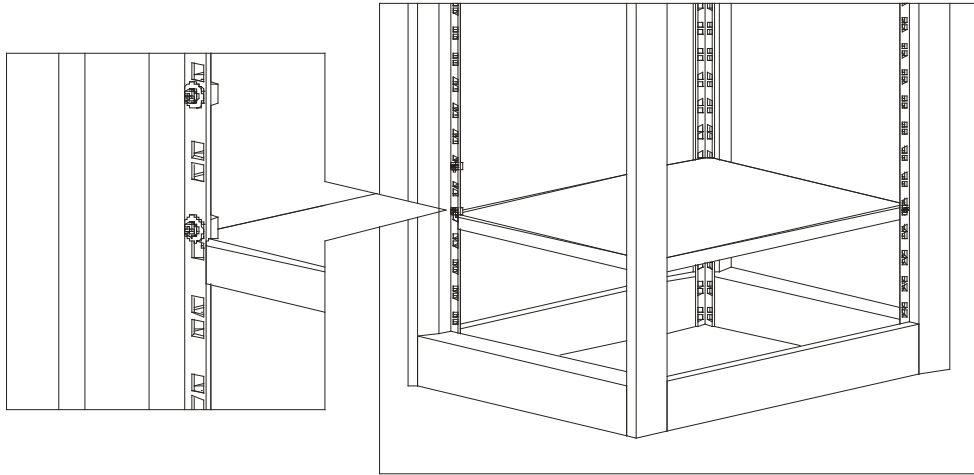

Step 4

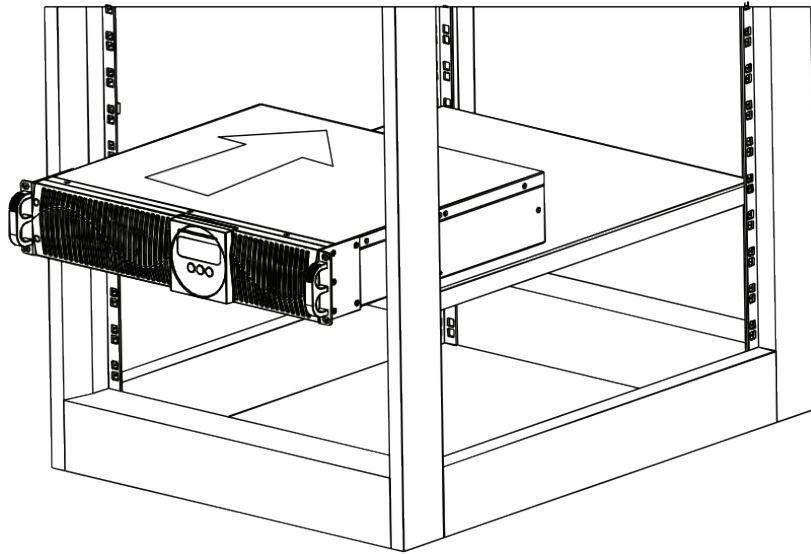

Step 5

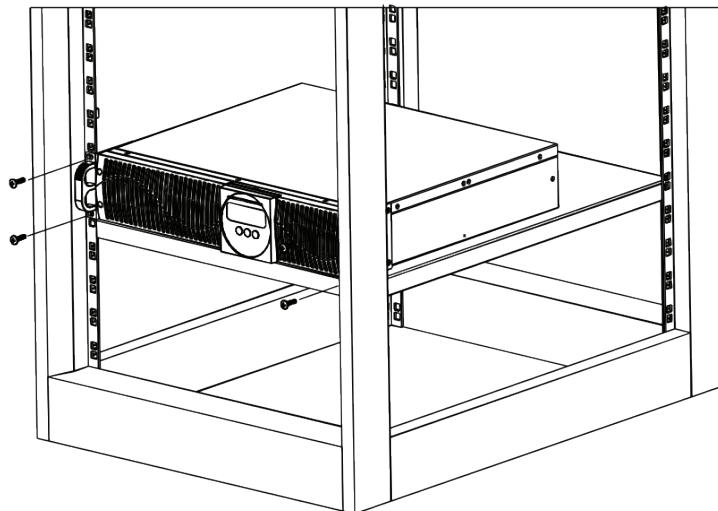

3.6 UPS Front Panel

The front panel can be rotated to accommodate the orientation of the UPS.

To position the display to match the physical orientation of the unit pull the display out, rotate it and then push it back in.

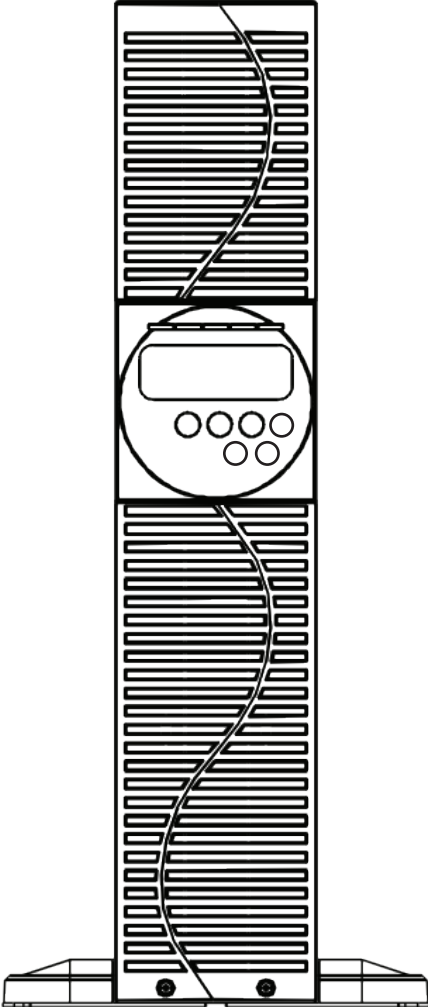
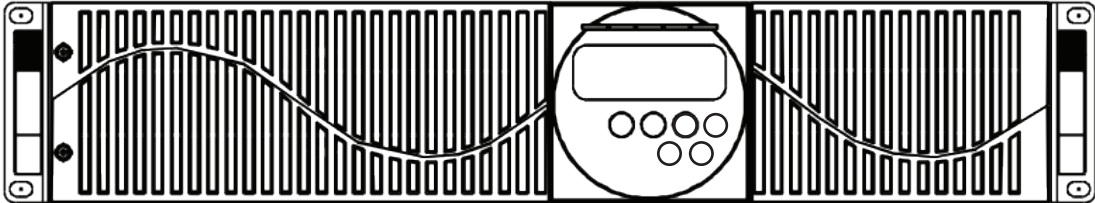

3.7 Rear Panel

3.7.1 120V

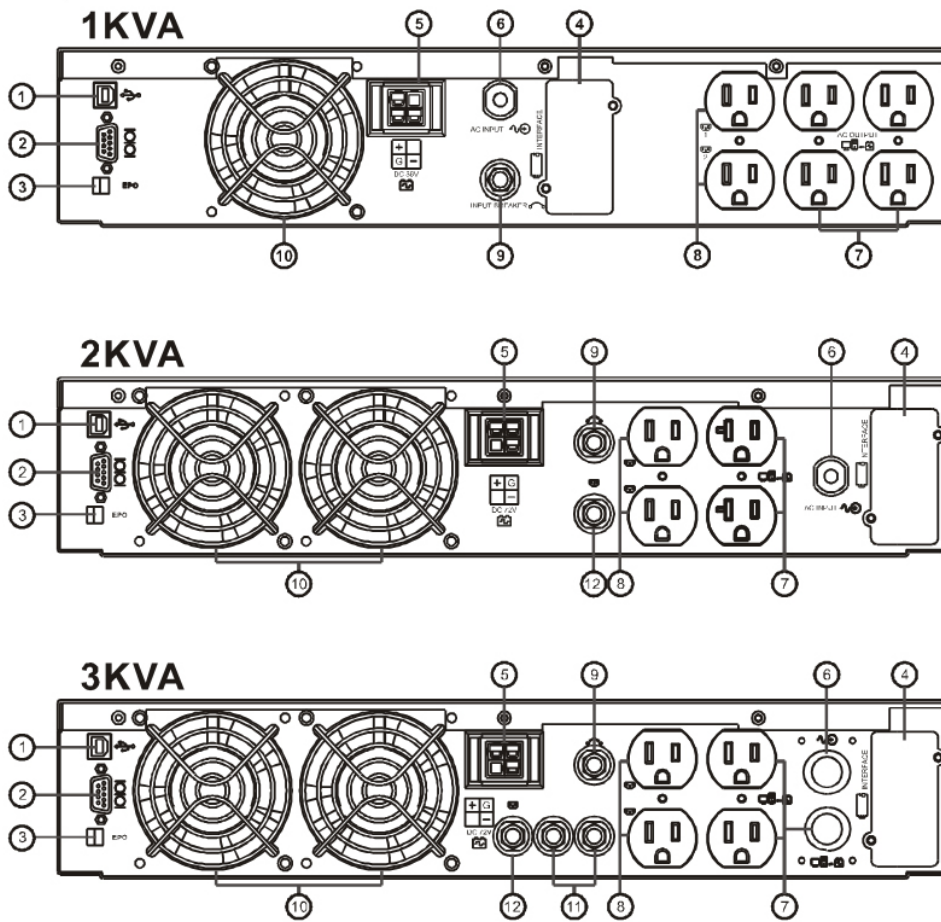

Item	Description
1	USB Port
2	RS232 Port
3	Remote Emergency Power Off (REPO)
4	Communication Card Options Slot
5	External Battery Connector
6	AC power connection socket
7	AC Outlets
8	Two programmable outlets
9	Utility Input circuit breaker
10	Cooling fans
11	Output circuit breaker for two outlets
12	Output circuit breaker for two programmable outlets

3.7.2 230V

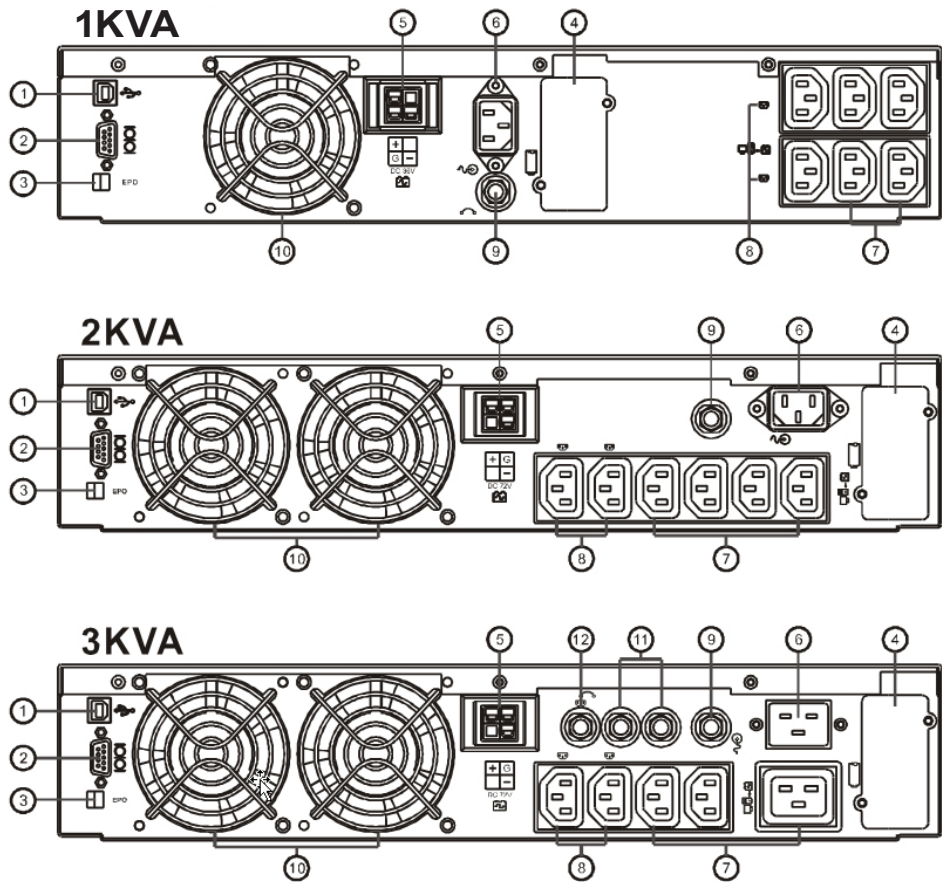

Table B — 1000/ 2000/ 3000 VA, 230 V	
Item	Description
1	USB Port
2	RS232 Port
3	Remote Emergency Power Off (REPO)
4	Communication Card Options Slot
6-1	External Battery Connector
6	AC power connection socket
7	AC Outlets
8	Two programmable outlets
9	Utility Input circuit breaker
10	Cooling fans
11	Output circuit breaker for two outlets
12	Output circuit breaker for two programmable outlets

3.8 Communication Ports

The UPS is equipped with a remote emergency power off (REPO) dry contact input, true RS232 and USB communication ports to provide communication with bundled UPS monitoring software for remote monitoring of UPS status via a PC.

Four optional interface cards are available to meet various communication needs (Refer to Section 7):

- DCE (dry contact relay card)
- RS232
- USB
- SNMP/WEB card

The bundled software of the UPS is compatible with many operating systems such as Windows 98, 2000, ME, NT and XP. For other applications such as Novell, NetWare, Unix, Linux, please contact your local dealer for suitable software.

All communication ports (including optional cards) can be active simultaneously to monitor the UPS status. However only 1 communication interface can be active at any one time. The interface with the highest priority controls the UPS. The priority of these communication interfaces are as follows from highest to lowest priority:

- EPO input port
- Optional Interface card
- USB
- RS232

3.8.1 RS232 Port Settings

Set the RS232 interface as follows:

Baud Rate:	2400 bps
Data Length:	8 bits
Stop Bit:	1 bit
Parity:	None

3.8.2 USB Port Descriptions



The USB communication protocol definition complies with

- USB version 1.0, 1.5Mbps
- USB HID Version 1.0.

4. Installation

4.1 Connecting Utility and Load

The UPS outlets provide battery backup and surge protection for the equipment when the utility voltage is out of range.

1. Make sure the utility voltage is within the UPS voltage limits.
2. Plug the UPS into a utility power receptacle.
3. Illumination of the green Utility LED  and the amber Bypass LED  indicate that utility and bypass are normal.
4. The LCD screen updates as shown:

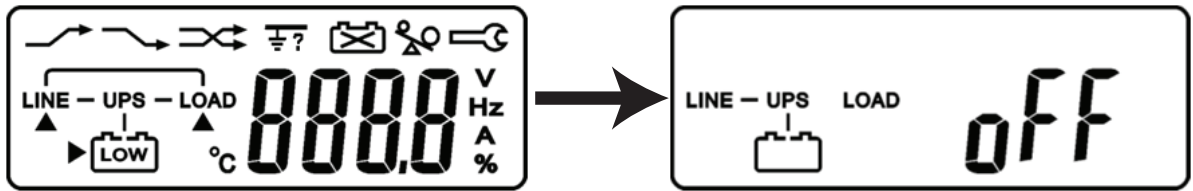

5. Plug a computer and monitor into two of the non-programmable outlets.

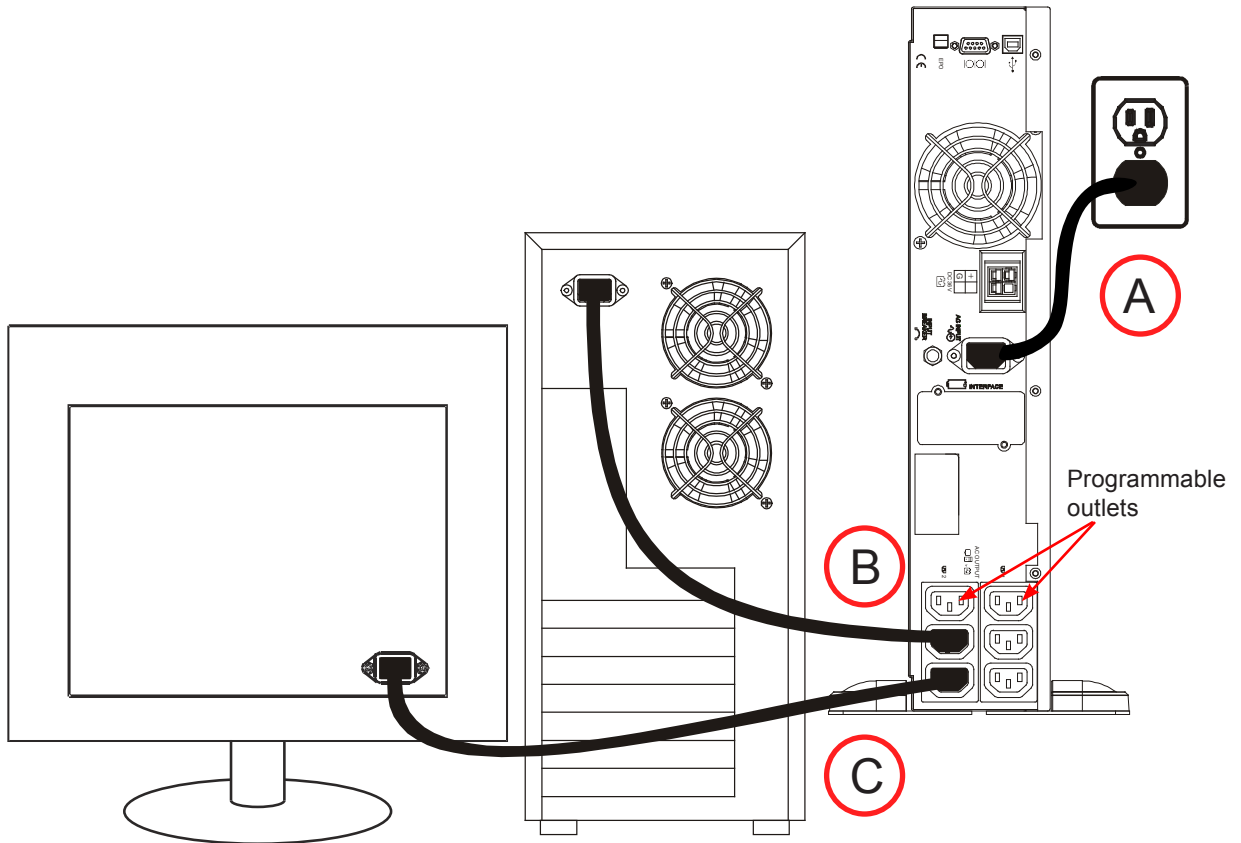

CAUTION!

Do not connect a laser printer to the UPS outlets! The printer may overload the UPS and shut it down.

- At the UPS, press and hold the **ON** switch for approximately 3 seconds until the buzzer sounds twice.
- The Initialize screen appears and the UPS automatically runs a self-test sequence.
- Start-up of the UPS is complete when the Input Voltage screen appears.

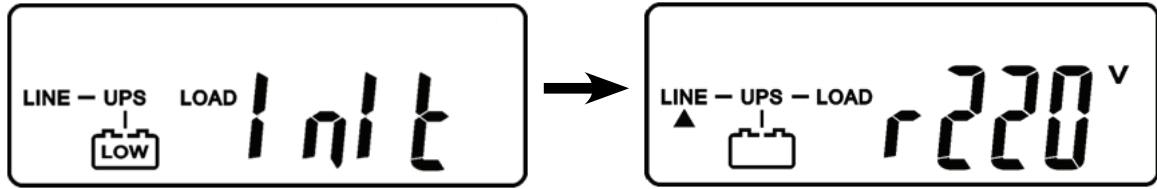

NOTE:
 At this point the UPS batteries are charging. Plug the UPS into the wall receptacle to charge the UPS for at least 4 hours after the initial installation.

4.2 Connecting the Computer Interface Port

This section is intended for use of the UPS Setting Tool over a RS-232 connection.

Use the supplied RS-232 cable to connect the interface port on the rear of the UPS to the computer interface port.

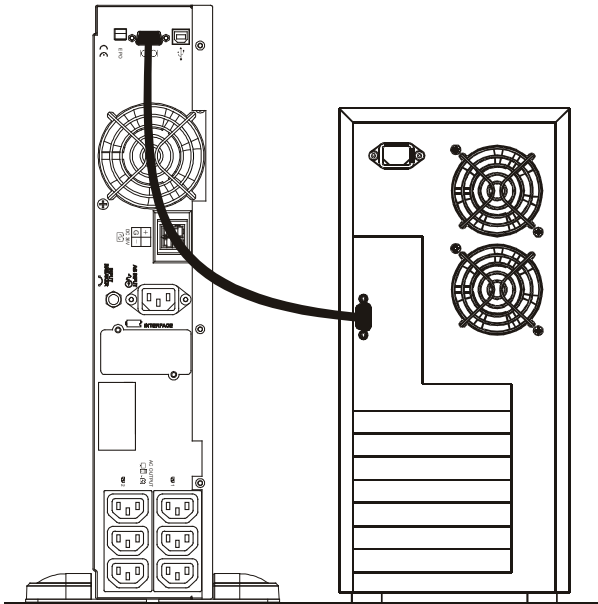

4.3 Operating Modes and Voltage System Configuration

- Load the supplied UPS Setting Tool CD and install the software.

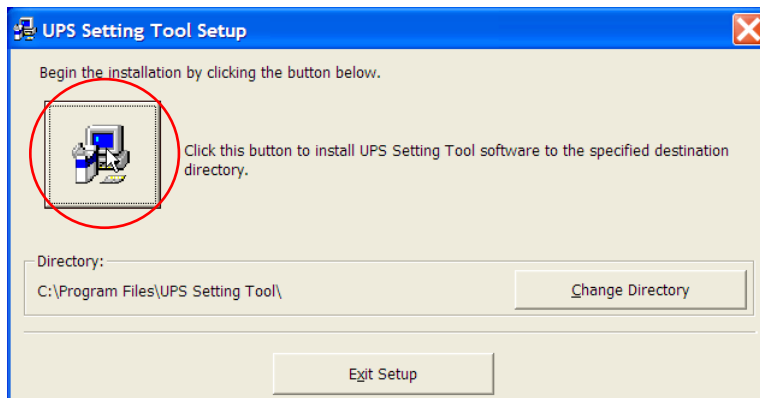

- In the first UPS Setting Tool screen, select your computer's **Com Port** from the drop down menu.

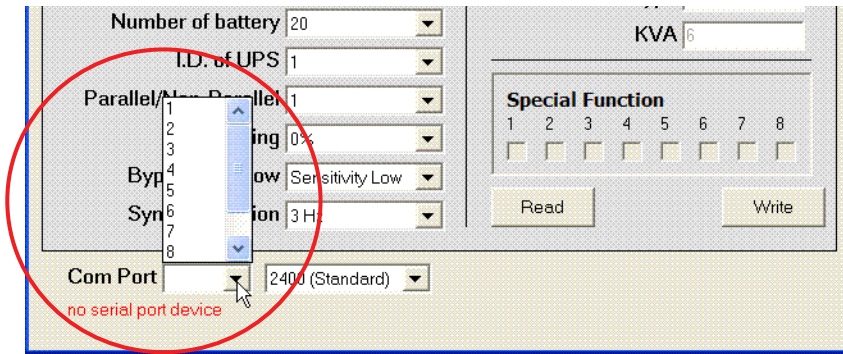

- When serial communications are established between the UPS and your computer, the following screen appears.

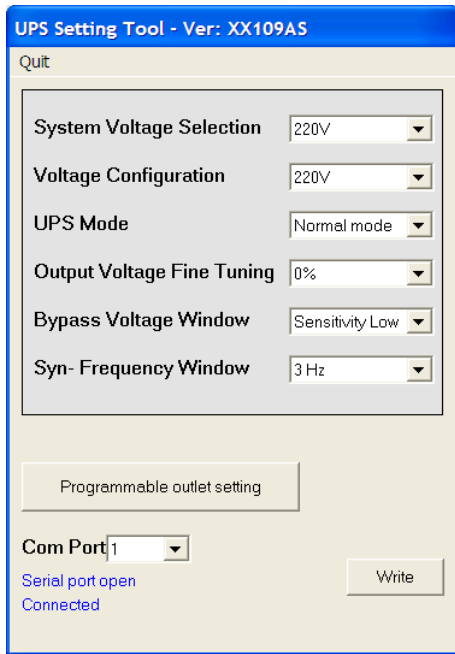

- Configure the settings as follows:

System Voltage Selection	Select Input Voltage 110V* or 220V*	
Voltage Configurations	Select UPS Output Voltage 200V/208V/220V/230V/240V or 100V/110V/115V/120V/127V	
UPS Modes	Select Normal/ CF50** /CF60** Mode	
Output Voltage Fine Tuning	Output Voltage Regulation from 0 to ~±3%	
Bypass Voltage Windows	Sensitivity Low	Sensitivity High
120V System	90V~130V	97V~130V
230V System	180V~260V	194V~260V
Syn-Frequency Window	Select 3Hz/ 1Hz Inverter Freq synchronizing range	
Com Port	Displays curent PC Com Port	
*Select 110V for a 120V input; select 220V for a 230V input		
**CF50/ CF60 = Frequency Converter mode 50 to 60Hz or vice versa		

- Click **Write** to confirm the configuration settings. The UPS beeps twice if the new settings are saved successfully. Note that the settings do not take effect until you restart the UPS at the end of this section.

Configuring the Programmable Outlet 1/ Programmable Outlet 2

The UPS is equipped with 2 programmable outlets to supply less critical loads. These outlets can be configured to disconnect the less critical loads during back-up modes or overload conditions to preserve power to the more critical loads connected to the UPS.

- Click **Programmable outlet setting** in the **UPS Setting Tool** window. The Programmable Outlet Setting screen appears.

The screenshot shows a window titled "Programmable Outlet Scheme" with a close button in the top right corner. The main content is titled "Programmable Outlet Settings" and is divided into three sections:

- Programmable Outlet 1:** Contains five settings, each with a checkbox, a numeric input field, and a unit label:
 - Outlet Turn On, After UPS On: Input field "0", unit "Second (0-3600)".
 - Outlet Turn Off, After AC Failure: Input field "0", unit "Second (0-3600)".
 - Outlet Turn On, After AC Recovery: Input field "0", unit "Second (0-3600)".
 - Outlet Turn Off, When Battery Low: Input field "50", unit "% (20-80)".
 - Outlet Turn Off, When UPS Overload: A "Setting" button.
- Programmable Outlet 2:** Contains the same five settings as Programmable Outlet 1.
- Manual Control Switch:** Contains two sections, one for Programmable Outlet 1 and one for Programmable Outlet 2. Each section has two buttons labeled "On" and "Off".

- Use the following guidelines to set the parameters for the operation of the programmable outlets.
 - Outlet Turn On After UPS On** – enable the outlet within the time specified when the UPS is powered on. A value of 0 enables the outlet once the UPS is powered on.
 - Outlet Turn Off After AC Failure** – disable the outlet within the specified time after utility outage.
 - Outlet Turn On After AC Recovered** – enable the outlet within the specified time after the utility is restored.
 - Outlet Turn Off When Battery Low** - disable the outlet at the specified remaining battery power capacity(%) during battery mode to disconnect the less critical loads.
 - Outlet Turn Off When UPS Overload** – disable the outlet during overload condition (bypass mode) to possibly allow the more critical loads to be continually supplied via Bypass without shut down.
- Click **Setting** to save the new parameters. The UPS beeps twice if the new settings are saved successfully. The setting do not take effect until the system is powered off and on.



NOTE:

Use the **On** or **Off** buttons under **Manual Control Switch** to manually enable or disable the programmable outlets, overriding all previous settings.

Restarting the UPS

- Press the **OFF** button for 5 seconds. The buzzer sounds twice and the "off" screen displays.
- Unplug the power cord from the AC power utility receptacle.
- After three seconds, reconnect the power cord and restart the computer (See Section "5.2.1 Start Up In Normal Mode" on page 22.)
- Plug the UPS into the wall receptacle to charge the UPS for at least 4 hours after the initial installation.

4.4 REPO Switch

The UPS is equipped with a remote emergency power off (REPO) switch. The user must supply a means of interfacing with the REPO circuit so that the UPS input feeder breaker can be switched off to interrupt all sources of power to the UPS and connected equipment. This requirement complies with national and local wiring codes and regulations.

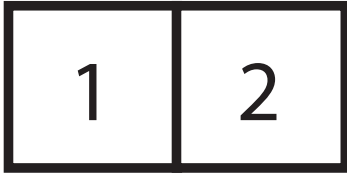

1 = REPO+

2 = Ground

Short Pin 1 and Pin 2 to enable the REPO function

5. Operation

5.1 Front Panel LCD

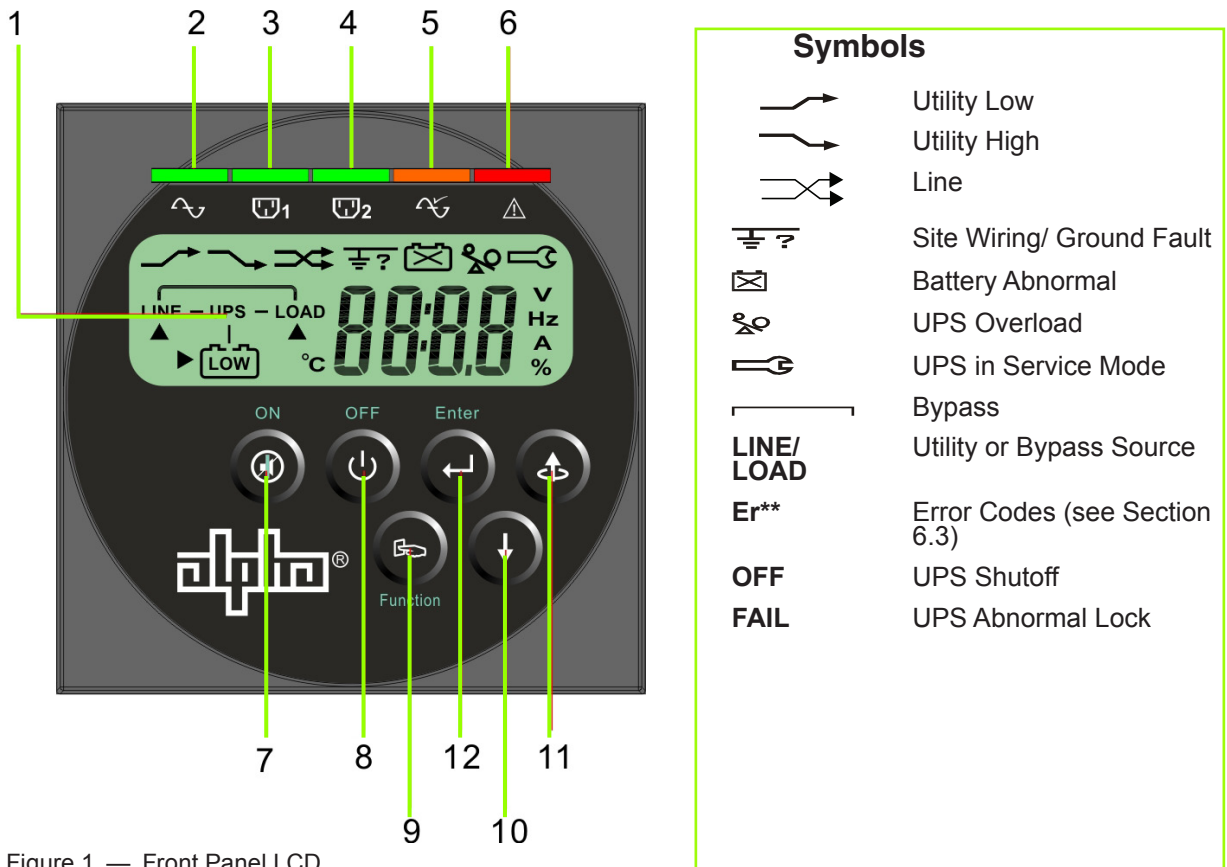



Figure 1 — Front Panel LCD

Table C — LCD Panel Description

Item	Description
1	LCD display
2	Green Utility LED illuminates to indicate that the Utility input voltage is within the range 80Vac~144Vac, or 160Vac~288Vac; the LED flashes to indicate that the Utility input voltage is within the range 60Vac~79Vac, or 120Vac~159Vac.
3, 4	Green LEDs for Programmable Outlet 1 and Programmable Outlet 2 illuminate to indicate power is available at the outlets.
5	Amber LED illuminates to indicate the Bypass input is normal.
6	Red Fault LED
7	ON/Alarm silence button
8	OFF button
9	Special functions log in/out
10	SCROLL DOWN key: Go to next page
11	SCROLL UP key, Go to previous page or change the setting of the UPS
12	Enter key: to confirm the change of a UPS setting
Manual Bypass	Press and hold the ON key (7) and the SCROLL UP key (11) simultaneously for ~3 seconds to transfer from Inverter to Bypass (the amber Bypass LED blinks continuously and the buzzer beeps intermittently) OR from Bypass to Inverter, when the UPS is on Line Mode and the Bypass Voltage Window is Normal.

5.2 Start Up from the LCD Panel

5.2.1 Start Up In Normal Mode

1. Make sure the utility voltage is within the UPS voltage limits.
2. Connect the UPS to the utility wall receptacle.
3. Illumination of the green Utility LED  and the amber Bypass LED  indicate that utility and bypass are normal.
4. The LCD screen changes from A to B as shown

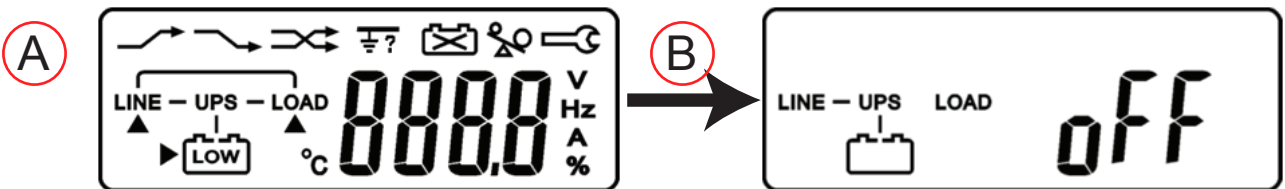

5. Press and hold the UPS **ON** switch for approximately 3 seconds until the buzzer sounds twice.
6. Screen C appears and the device automatically runs a self-test sequence.
7. Start up of the UPS is complete when the Input Voltage screen (E) appears. If the self-test fails, the LCD screen appears as shown in screen D. An error code or error status shows on the screen.

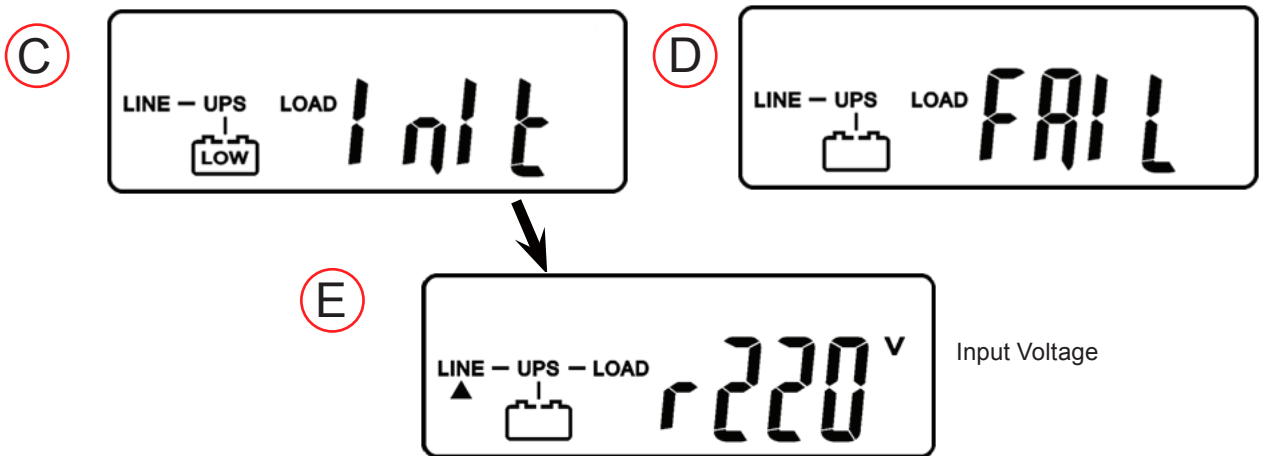

8. The charger starts charging the batteries
9. Leave the UPS plugged into the wall receptacle for at least 4 hours to allow the UPS batteries to charge fully.

5.2.2 Start-up in Battery Mode (Cold Start)

1. Make sure the UPS has been installed complete with batteries.
2. Press and hold the UPS ON button for 3 seconds. The buzzer sounds twice. The LCD displays screen F.

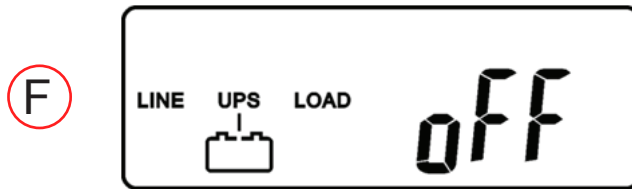

3. Press and hold the UPS **ON** button for 3 seconds until the LCD display changes from screen F to screen G.

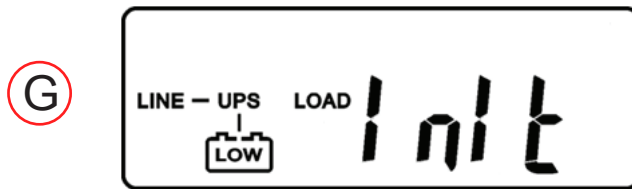

4. The UPS automatically runs a self-test. In about a minute, the UPS supplies power to the output and the LCD updates to screen H.
If this process fails, the UPS will switch off in 10 seconds.

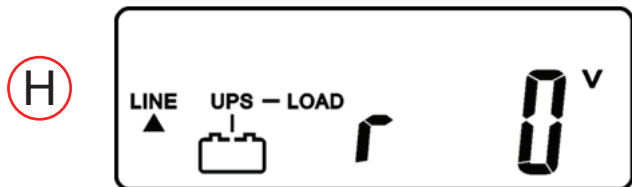

5.2.3 Check Measured Values and Figures (detected by UPS)

To check the measured values and messages, use the UP  and DOWN  keys.

When you scroll with the DOWN key, the LCD shows in sequence:

- Screen E (Input Voltage)
- Screen J (Input Frequency)
- Screen K (UPS Output Voltage)
- Screen L (UPS Output Frequency)
- Screen M (UPS Output Load percentage)
- Screen N (UPS Battery Voltage)
- Screen O (UPS inner temperature)

J



Input frequency

K

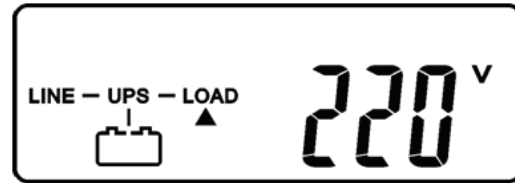

UPS output voltage

L

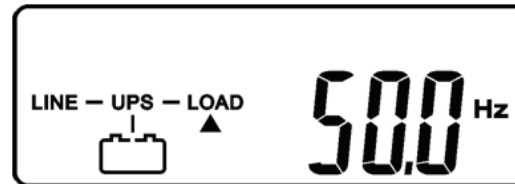

UPS output frequency

M

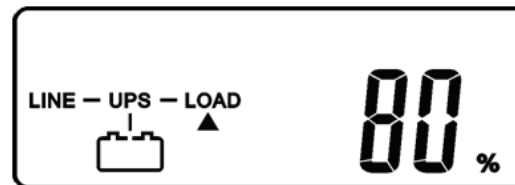

UPS output load percentage

N

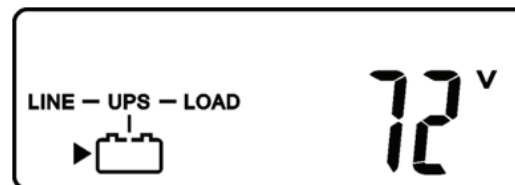

UPS battery voltage

O

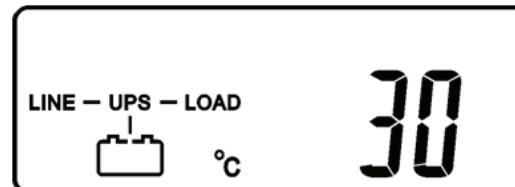

UPS inner temperature

5.2.4 UPS Default Data and Special Function Execution

To run a self test or check default data, press the **Function** button to scroll to screen P1.



Press the DOWN button to scroll through the LCD screens and check the UPS settings. The LCD display shows the following screens in sequence:

- Screen P1 (buzzer)
- Screen Q1 (self test)
- Screen R1 (Bypass Voltage)
- Screen S (Output Frequency Synchronized Window)
- Screen T (Inverter Output Voltage)
- Screen U1 (UPS Operation Mode)
- Screen V (Output Voltage Fine Tuning)

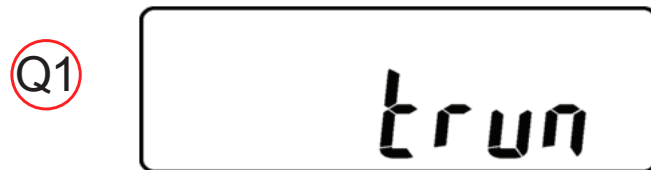

Acceptable bypass
input

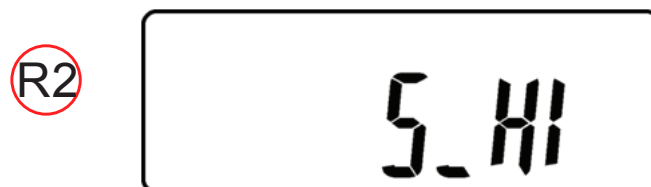

Acceptable bypass
input

S

5103 Hz

Bypass frequency

T

0220 V

Inverter output voltage

U1

norL

UPS operation mode:
Online

U2

cF50 Hz

UPS operation mode:
fixed 50HZ output

U3

cF60 Hz

UPS operation mode:
fixed 60HZ output

V

0A 0 %

Inverter output calibration

Press the **UP** button to execute the following special functions:

- Buzzer ON (screen P1) or buzzer OFF (screen P2)
- Alarm silence for UPS warning
- Self-test ON (screen Q1) or Self-test OFF (screen Q2)

The UPS executes a battery test for 10 seconds. If the battery test is successful, the LCD displays screen W; otherwise screen D appears with an error message.

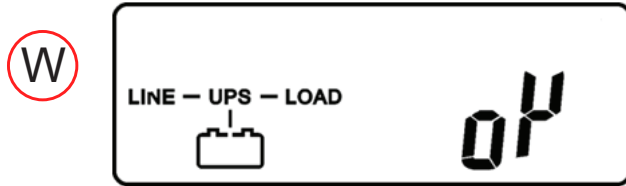

5.2.5 Changing the UPS Default Settings

1. Make sure the UPS is not switched on, that is, not in Line mode or Backup mode.
 2. Simultaneously press and hold the **ON** button and the **DOWN** button for ~3 seconds. The buzzer sounds twice and the LCD display screen updates to screen P1.
- The UPS is now in setup mode. Except for the buzzer (screens P1 and P2) and self-test (screens Q1 and Q2) settings, all default settings can be changed by pressing the UP button.

3. Screens R1 and R2 show the bypass input limits; Acceptable values are 180VAC~ 260VAC for a 230VAC system, 90VAC~130VAC for 120VAC system or 194VAC~260VAC for 230VAC system, 97VAC~130VAC for 120VAC system.
4. Screen S shows the bypass frequency window of the inverter output, the acceptable setting values are +/-3Hz and +/-1Hz.
5. Screen T shows the acceptable Inverter Output Voltage: 200V, 208V, 220V, 230V, 240V for 230VAC system, or 100V, 110V, 115V, 120V and 127V for .
6. Screens U1, U2 and U3 show the operation modes of the UPS: Online, fixed 50Hz output or fixed 60Hz output.
7. Screen V shows the inverter output settings, which can be set to 0%, +1%, -1%, +2%, -2%, +3%, or -3%.
8. When all the setting have been entered, Screen X appears. Press the ENTER button to save the



changes. These changes do not take effect until the UPS is restarted.

9. Switch off the UPS and the utility input breaker.
10. Restart for the changes to take effect.

5.2.6 UPS Is Off for Unknown Reasons

If a serious abnormal condition occurs, the UPS locks as shown in screen Y.

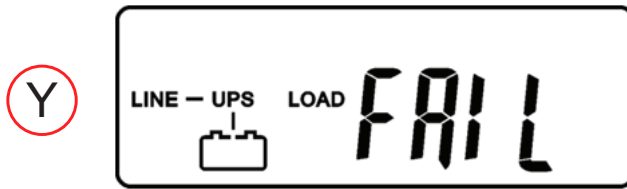

In most abnormal conditions, the UPS maintains bypass output; however, when it is outside of bypass window settings, the UPS is locked and the abnormal status is shown as screen Z.

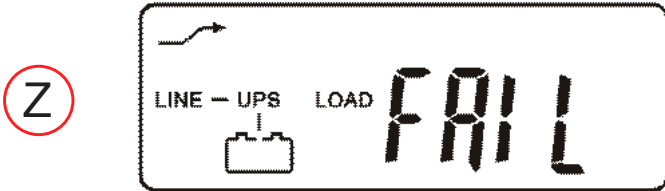

To release the UPS lock, proceed as follows:

1. Check the error messages in Table D in Section 6.3 to troubleshoot the problem. If necessary, contact your local distributor for service.
 2. Press the **OFF** button for 5 seconds. The buzzer sounds twice.
 3. Switch off the utility input breaker.
- t

5.2.7 Shut Off

1. Press and hold the OFF button for about 5 seconds: the Inverter output switches off and the UPS stops supplying power to the loads. The LCD displays screen B.
2. Switch off the utility input breaker.

The UPS is now completely turned off.

5.2.8 Status and Alarm Buzzer

The following table shows the corresponding beeps for each UPS status.

Status	Buzzer Beep Descriptions
UPS faulty, Inverter shutdown. All functions inhibited.	Long Continuous Beep
UPS faulty, loads continue to be supplied via Inverter or Bypass.	Single successive beep with ~ 2 sec interval
Battery mode	Single short successive beep with ~1 sec interval
Battery low	Very quick and short successive beeps
Confirm/RS232 port receiving	2 short beeps
Service mode OK	1 short beep
Initial start up in self-test mode	2 successive quick & short beeps, repeating per ~2 sec interval.

6. UPS Maintenance

6.1 Battery Replacement Precautions

This UPS is intended for use with a maximum of one extension battery pack. Refer to Section 6.2 for the installation procedure.

The following precautions apply when replacing batteries in a SERVICE ACCESS AREA:

- Servicing of batteries should be performed or supervised by personnel knowledgeable about batteries and the required precautions.
- There is a risk of explosion if a battery is replaced by an incorrect type. When replacing batteries, replace with the same type and number of batteries or battery packs.



CAUTION!

Do not dispose of batteries in a fire. The batteries may explode. Dispose of used batteries according to the instructions.



CAUTION!

Do not open or mutilate batteries. Released electrolyte is harmful to the skin and eyes. It may be toxic.

6.2 Battery Replacement

When the UPS is started up or a self-test is executed, the battery replacement symbol on the LCD panel may appear because of a weak or dead battery.

1. If the battery replacement symbol on the LCD panel appears, charge the UPS for at least 8 to 10 hours. The symbol should disappear after the self-test function has executed.
2. If the battery replacement symbol stays on after charging, unscrew the battery cover and replace the battery as shown in the following sections.



CAUTION!

A battery can present a risk of electrical shock and high short circuit current. The following precautions should be observed when working on batteries:

- a. Remove watches, rings, or other metal objects.
- b. Use tools with insulated handles.
- c. Wear rubber gloves and boots.
- d. Do not lay tools or metal parts on top of batteries.
- e. Disconnect charging source prior to connecting or disconnecting battery terminals.
- f. Determine if the battery is inadvertently grounded. If inadvertently grounded, remove source from ground. Contact with any part of a grounded battery can result in electrical shock. The likelihood of such shock can be reduced if such grounds are removed during installation and maintenance (applicable to equipment not having a grounded supply circuit).



CAUTION!

The UPS will not provide any output power if the start-up procedure has not completed properly even though the input power cord is connected to the wall receptacle.



CAUTION!

The battery is heavy, pull the battery out onto flat, stable surface.



CAUTION!

Do not disconnect the batteries while the UPS is in the backup mode.



CAUTION!

Use caution when replacing live batteries.

6.2.1 To Replace the Batteries

STEP 1

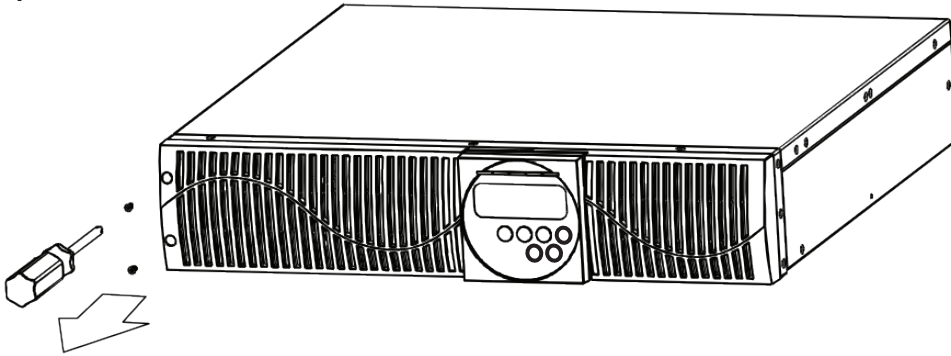

STEP 2

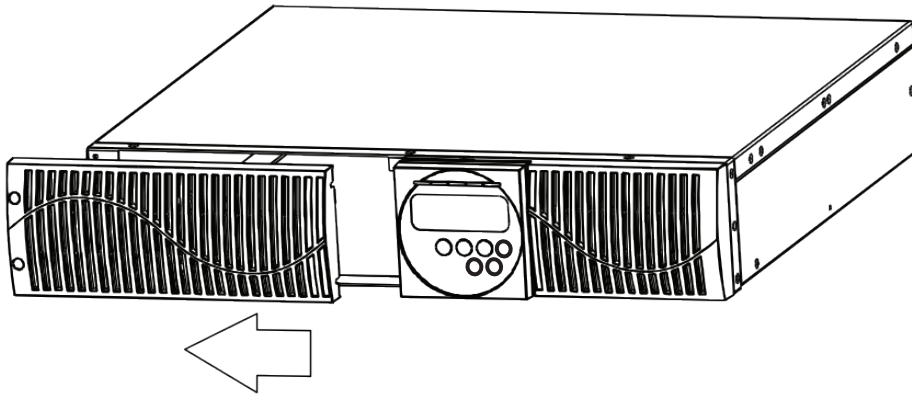

STEP 3

1000 VA

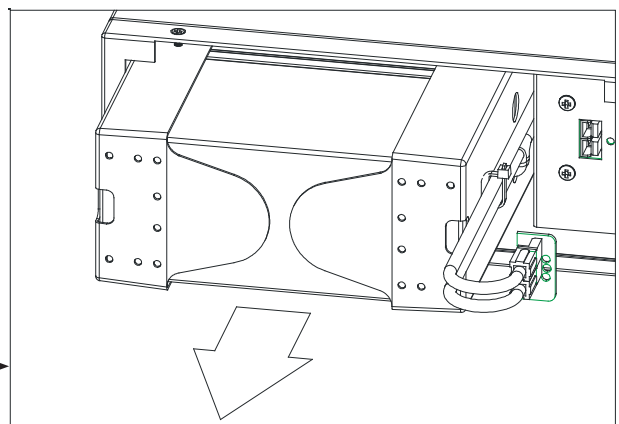
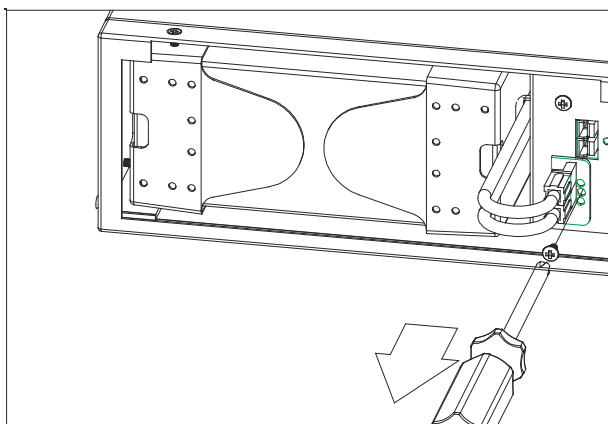

STEP 3

2000/ 3000 VA

Use scissors to cut the tie wraps.

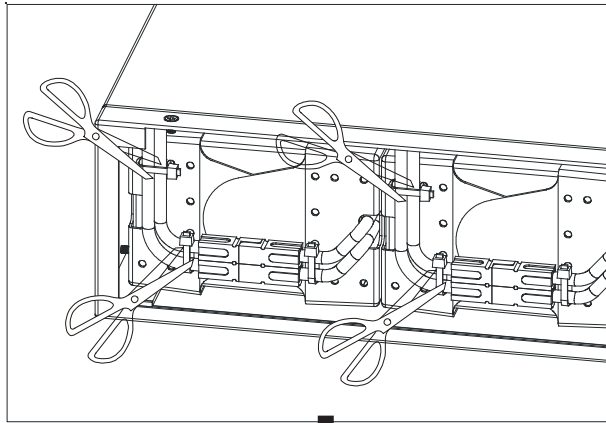

Disconnect the cables.

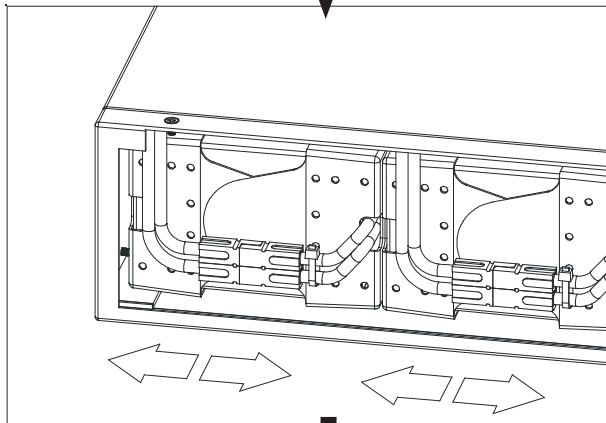

Remove the batteries.

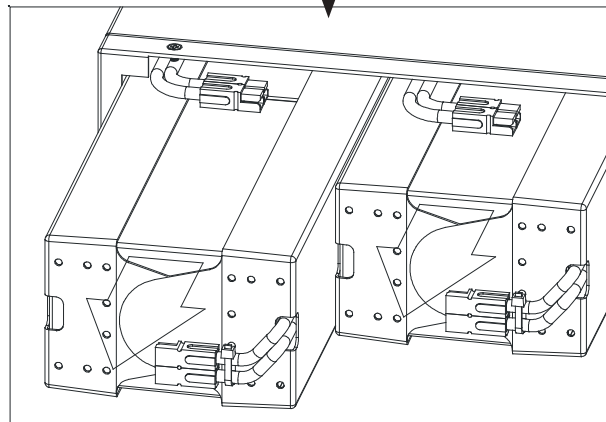

6.2.2 Recycling Used Batteries

Contact your local recycling or hazardous waste center for information on the proper disposal of used batteries.

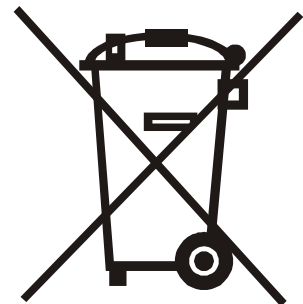

6.3 Troubleshooting

When the UPS becomes faulty or malfunctions during operation, check the fault table for possible solutions. Should the problem persists, please contact your local dealer for assistance.

6.3.1 Error Codes

LCD Panel

If an abnormal condition has occurred, the Fault LED illuminates and the buzzer sounds.

Press the LCD OFF key briefly to view the error message.

Do NOT hold the OFF key for over 5 seconds as the unit will shut off.

Table D — Error Codes	
Code	Descriptions
Er05	Battery weak or faulty
Er06	Output short-circuited
Er07	REPO mode
Er11	UPS over-temperature
Er12	Inverter overload
Er14	Fans out of order
Er18	EEPROM's data error
Er24	Utility Low (<85/170V) and Battery Disconnected
Er28	Bypass overload
Er31	EEPROM data does not conform to the Jumper Setting

Table E — Troubleshooting Table

Situation	Error Indication	Solution
<p>UPS Fault  LED</p> <p>Refer to Table D for error codes).</p>	Er05	<p>Check battery connection.</p> <p>Measure Battery voltage to ensure batteries are charged or healthy. Recharge batteries for 4 hours if necessary.</p> <p>Simulate Utility outage to verify if UPS is able to provide DC back-up.</p> <p>Otherwise consult your local dealer right away.</p>
	Overload	<p>Disconnect some non critical loads from the UPS output until overload ceases.</p> <p>Check for short circuit between cables due to broken cable insulator. Replace the cables in necessary.</p>
	Er11 (UPS over Temperature)	<p>Remove any objects obstructing the ventilation louvers.</p> <p>Verify if the cooling fans are working properly.</p> <p>Contact your local dealer to replace the fans if necessary.</p>
	Site wiring/ Ground fault	<p>Verify if the L and N phase of the Utility AC source is incorrectly wired or if the Ground-Neutral Voltage exceeds the limits</p>
	Er14 (Fans out of order)	<p>Verify ventilating fans are functioning.</p> <p>Do not attempt to replace the fans by yourself. Contact your local dealer for replacement</p>
	Other error codes	<p>Consult your local dealer for assistance.</p>
<p>UPS fails to provide battery backup or its back up time is shorter than its intended performance.</p>		<p>If the backup time remains unsatisfactory after 4 hours of charging, contact your local dealer for battery replacement.</p>
<p>UPS is normal but no Output to load</p>		<p>Check that all power cords are properly connected.</p> <p>If problem persists, consult your local dealer for technical assistance.</p>
<p>The UPS switches to battery mode then back to Utility mode, when a connected device is turned on. Or, The UPS switches back and forth between battery and utility.</p>		<p>If a power bar is connected to the UPS, Do not use the power bar.</p> <p>Check for damage to the utility wall receptacle, cable, or plug. replace if necessary.</p>

Table E — Troubleshooting Table		
Situation	Error Indication	Solution
Strange noise and smell		Immediately shut down the whole System. Disconnect the power from the UPS and call for service.
UPS is unable to provide backup power source		<p>Check that the battery connectors are fully engaged.</p> <p>Allow the battery to recharge if the battery is weak.</p> <p>If problem persists after recharging, replace the battery.</p> <p>If problem persists consult your local dealer for technical assistance.</p>

7. Optional Communication Cards

All of the following cards can be installed in the optional slot:

- R2E (2nd RS-232) card
- USB card
- DCE (Dry Contact) card
- SNMP cards

7.1 R2E (2nd RS-232) card

CN1 is for RS232 DB9.

For communication protocol, refer to 3.8 on page 15.

7.2 USB card

CN1 is for USB.

7.3 DCE (Dry Contact) card

The pin assignments of 10-Pin Terminal

1	2	3	4	5	6	7	8	9	10
Pin	Function								
1	UPS on Bypass mode (Bypass)								
2	Utility Normal (Normally close contact)								
3	Utility Normal (Normally open contact)								
4	Inverter On								
5	Battery Low								
6	Battery Bad or abnormal								
7	UPS Alarm								
8	Common								
9	Shutdown UPS positive(+) signal								
10	Shutdown UPS negative(-) signal								

The shutdown function is activated, after +6 to +25 VDC is put between pin 9 and pin 10 for 5 seconds.

The capacity of each relay contact is 40VDC/25mA.

Flexible signal output for NC (normally closed) or NO (normally open) contact by shorting pin 1 to 2, or pin 2 to 3 from JP1-5.

The shutdown function is enabled 1 minute after blackout occurs if pin 1 to 2 of both CN1 and CN6 are shorted. Or, the shutdown function can only be enabled by pin9-10 of CN3 if pin2-3 of both CN1 and CN6 are shorted.

7.4 SNMP Cards

7.4.1 SNMP/WEB card

For installation, refer to the user's manual that comes with the card.

8. Specifications

Table F — Specifications				
Model		Continuity 1000	Continuity 2000	Continuity 3000
VA rating				
Apparent Output Power		1000VA	2000VA	3000VA
Active Output Power	PF=0.8	800Watts	1600Watts	2400Watts
Power Factor		0.8		
Topology		Double conversion On-Line		
Type		Rack/Tower		
Agency Approvals		115V Models: UL, cUL, FCC		
		230V Models: CE		
Input				
Voltage Window	115V	60/70/80 - 144VAC		
	230V	120/140/160 - 288VAC		
Voltage Range	Based on load percentage (0~33/33~66/66~100%)			
	Low Line Transfer	115V	60/70/80VAC	
		230V	120/140/160VAC	
	Low Line Comeback	115V	85VAC	
		230V	170VAC	
	High Line Transfer	115V	144VAC	
		230V	288VAC	
	High Line Comeback	115V	139VAC	
230V		278VAC		
Frequency		50/60 Hz auto-select, \pm 5Hz		
Phase		Single phase with ground		
Power Factor		>0.99 at full rated linear load		
Transfer time		0 ms typical		
Waveform	115V	\leq 5mA		
	230V	\leq 3.5mA		
Surge protection	115V	400 joules		
	230V	300 joules		

Output				
Output - INV mode	Voltage		120V nominal	
			230V nominal	
	Voltage Regulation		≤ ± 1% until low battery warning	
	Frequency(Synchronized Range)		3Hz or 1Hz (setting by software)	
	Frequency(Battery Mode)		±0.1% (0.05~0.06Hz) unless synchronized to line	
	Current Crest Factor	PF=0.8	2.7:1	
	Harmonic Distortion		1KVA,2KVA, 3KVA ≤ 3% THD(Linear Load) 1.5KVA ≤ 4% THD(Linear Load) ≤ 7% THD(Non-Linear Load)	
	Transient Response (ms)		≤ 60ms/±5%	
	Waveform		Pure sine wave	
Efficiency	To AC Mode (Full load)		85%	85%
	To Battery Mode (Full load)		83%	83%
Battery Parameters				
Model number		Continuity 1000	Continuity 2000	Continuity 3000
Type		12V/7.2Ah	12V/7.2Ah	12V/9Ah
Number of Batteries		3	6	6
Backup Time (Full Load)	PF=0.8	>5min.	>5min.	>4min.
Recharging Time		4 Hours to 90%		
Charging Current (Max.)		1.8A	2.16A	2.7A
Charging Voltage		41.0Vdc ±0.5V	82.0VDC ±0.5V	82.0VDC ±0.5V
Hot Swappable Battery		Yes		
Internal battery		Yes		
DC leakage current		≤ 30uA (±10uA) with no AC applied and the unit in the off position		
Battery type		Sealed, non-spill, maintenance-free, lead acid		
Transfer Time				
AC to DC		Zero		
Inverter to Bypass		2.5ms (Typical)	Zero	
DC Start		Yes		
Self Diagnostics		By button on the panel or Software Control		
Front Panel				
LED		Load Level/Battery Level/ Battery Mode/ Normal Mode/ Bypass Mode/ Self-Test/ Weak/Bad Battery/Site Wiring Fault/ Fault/ Overload/Programmable Outlet1//Programmable Outlet2		
Key		ON Button/ OFF Button/ (Test/Alarm Reset Button)		

Protection		
Overload	(AC Mode) <105% continuous >106%~120% for 30 sec transfer to bypass >121%~150% for 10 sec transfer to bypass >150% for immediate transfer to bypass Buzzer continuously alarms.	
	(Battery Mode) <105% continuous >106%~120% for 30 sec shut down >121%~150% for 10 sec shut down >150% for immediate shut down Buzzer continuously alarms.	
	(Bypass Mode) <105% continuous >106%~120% for 250 sec shut down >121%~130% for 125 sec shut down >131%~135% for 50 sec shut down >136%~145% for 20 sec shut down >146%~148% for 5 sec shut down >149%~157% for 2 sec shut down >158%~176% for 1 sec shut down >177%~187% for 0.32 sec shut down >188% for 0.16 sec shut down Buzzer continuously alarms.	
Short Circuit	Bypass mode : Input Fuse/Input Breaker Normal Mode: Output Breaker/Electronic Circuit Battery Mode: Output Breaker/Electronic Circuit	
Battery	ABDM	
EPO	UPS shuts down immediately	
Over Temperature	Normal Mode	Transfer to Bypass Mode
	Battery Mode	UPS shuts down immediately
Audible Alarm		
Battery Mode	Sounding once every 1.5 sec	
Low Battery	Sounding once every 0.2 sec	
Overload	Sounding once every 3 sec	
Fault	Continuously Sounding (or Sounding once every 3 second)	
Environmental		
Operating Temperature	+32°F to + 104°F (0°C to + 40°C)	
Storage Temperature	+5°F to + 104°F (-15°C to + 40°C)	
Relative Humidity	0% to 90%, non-condensing	
Noise Level	<50dBA	

Interface	
Interface Type	1 *USB port+ 1 *RS-232 port
SNMP(option)	Power management from SNMP manager and Web browser
Compatible platforms	Windows 2000/XP/7 Novell NetWare, Linux, etc.
Standards and Certification	
Safety	IEC/EN 62040-1-1, IEC 60950-1
Performance	IEC/EN 62040-3
EMC	IEC/EN62040-2 Class A, FCC Part 15 Subpart B Class A, IEC/EN55011, CISPR11, IEC61000-4-2/-3/-4/-5, IEC61000-2-2, IEC61000-3-2/-3
Markings	CE, UL, cUL, FCC

9. Warranty and Service Information

Technical Support

Free Technical Support 24/7/365 is part of the Alpha customer satisfaction commitment. The phone numbers below can also be used to access a wide range of service solutions both at your premise and at the Alpha facility nearest you.

In Canada and the USA, call toll free 1-888-462-7487 24 hours a day, seven days a week. Customers outside Canada and the USA, call +1-604-436-5547.

Warranty

Alpha Technologies Ltd. warrants its equipment to be free of manufacturing defects in material and workmanship, for a period of 36 months from the date of shipment from the factory. The warranty provides for repairing, replacing or issuing credit (at Alpha's discretion) for equipment shipped by it and returned by the customer to the factory or other authorized location during the warranty period.

There are limitations to this warranty coverage. The warranty does not provide to the customer or other parties any remedies other than the above. It does not provide coverage for any loss of profits, loss of use, costs for removal or installation of defective equipment, damages or consequential damages based upon equipment failure during or after the warranty period. No other obligations are expressed or implied. Warranty also does not cover damage or equipment failure due to cause(s) external to the unit including, but not limited to, environmental conditions, water damage, power surges or any other external influence.

The customer is responsible for all shipping and handling charges. Where products are covered under warranty Alpha will pay the cost of shipping the repaired or replacement unit back to the customer.

Battery Warranty

Battery warranty provided by Alpha is a three year full replacement warranty with a pro-rated warranty for the following two years. Pro rated warranty provides a credit applicable toward the purchase of new batteries from Alpha. The credit is calculated as the purchase price multiplied by the percentage of the battery life that was not available (in months). Battery warranty coverage is lost where the battery charge is not maintained for 6 months. Contact your Alpha sales representative or the Technical Support team at the above number to understand your entitlements under Battery Warranty.

Extended Warranty

The terms of warranty can be extended in time by purchase of an Extended Warranty. Warranty extensions are available on a per year basis and can be purchased during the initial warranty period.

Return of Material

Please contact Technical Support at the number above to obtain a Service Repair Order (or Return Material Authorization) number BEFORE sending material back. This will ensure that your service needs are handled promptly and efficiently.

On Site Services and Service Plans

A wide range of services are available at your location including installation, commissioning, preventative maintenance, remedial maintenance, battery replacement, battery delivery, etc. Preventative maintenance is recommended for Alpha products at least once per year. Customers can arrange to have these services provided automatically with one annual payment.

Service Centers

For a list of service centers, please visit:

<http://www.alpha.ca/web2/about-alpha/service-centers.html>

Appendix A

A-1 Theory of Operations

The UPS System Block Diagram below illustrates the true on-line double conversion architecture of the UPS system.

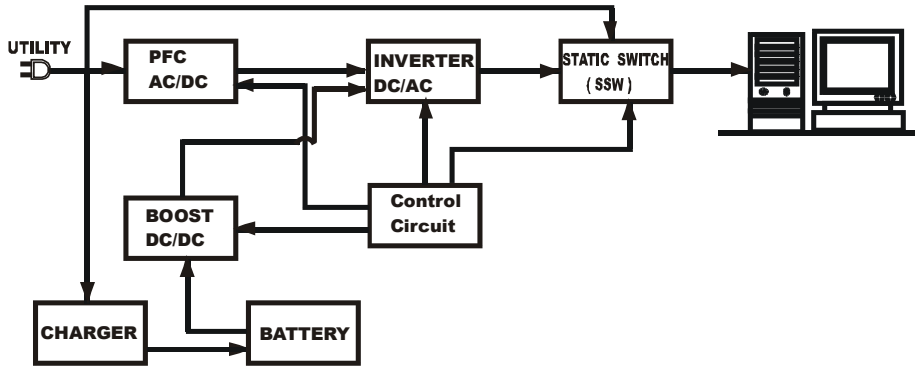

The major modules consist of the following:



- AC to DC power converter (rectifier) with a Power Factor Correction
- DC to AC power high frequency inverter
- Isolated intelligent battery charger
- Bank of stationary maintenance-free batteries
- DC to DC converter
- Static bypass loop
- Input and output EMI filters

The following table summarizes the UPS operating modes during various utility AC power conditions:

Utility Conditions	UPS Operating Modes	LED Display indications
Utility normal	Rectifier converts AC to DC. Battery charges. Inverter converts DC to AC and supplies the loads with clean, stable power.	, , LEDs illuminated
Utility abnormal (under or over voltage) or absent	Rectifier and charger stop operating. Battery discharges via DC-DC boost circuit and supplies the inverter. Loads continue to receive supply from the inverter. Buzzer beeps. UPS on battery mode.	green LED extinguished
Utility abnormal or absent, battery low voltage	Rectifier and charger stop operating. Battery discharges via the DC-DC boost circuit and supplies the inverter. Buzzer sounds short and frequent beeps, indicating that the battery power is low and the inverter will stop working at any moment.	LED extinguished LED illuminated symbol on LCD



The following sections describe the operation of the UPS under different conditions.

A-2 Utility is Normal

When the utility voltage is normal, the AC power is rectified to DC power, which is then fed into the inverter. The charger is switched to charge the batteries. The inverter transforms the DC power to clean AC power that supplies the loads. The , , and  LEDs are illuminated.

A-3 Utility Power is Abnormal/Absent

The working principle of the UPS when the utility power is abnormal is illustrated below: When the utility power is abnormal (under voltage, over voltage or absent), the UPS converts battery power to AC power through the DC-DC and DC-AC inverter. It also disables the AC-DC and charger sections. This happens instantaneously as the abnormality is detected.

1. When utility power returns to normal, the UPS switches to normal mode as explained in the previous section.
2. During a utility outage, the figure above illustrated the operation of the UPS. When the batteries are depleted, the buzzer beeps continuously until the unit is shutdown. The UPS low battery protection shuts off the output after a preset threshold to avoid over-draining the batteries. The  (battery low) &  (battery abnormal) symbols appear on the LCD until the UPS is completely shut off. The UPS re-starts automatically when the utility is restored.

A-4 Overload Condition

1. Most electronic and IT equipment draw an inrush current when turned on. The amplitude and duration of the inrush current varies depending on the equipment. Some inrush currents can be as high as six times the rated capacity while some equipment produce negligible inrush currents. To prevent severe inrush current damage to the inverter, the UPS is equipped with an electronic overload protection feature. If the UPS load is between 105 and 120% of its capacity, it switches to the bypass mode after 30 seconds to protect the inverter. If the overload condition is removed, the UPS switches back to inverter mode. If the UPS load is more than 150% of its capacity, the inverter shuts down immediately.
2. The UPS bypass loop is also equipped with overload protection. Its overload capacity is illustrated by the graphs and table below.

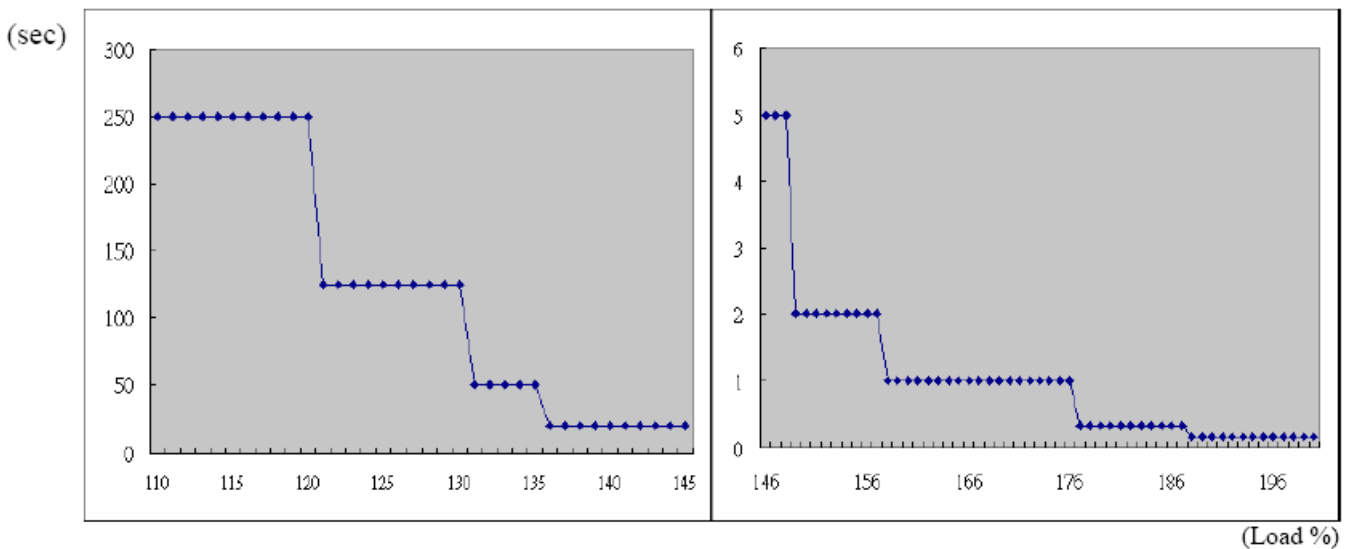

Load (%)	110~120	121~130	131~135	136~145	146~148	149~157	158~176	177~187	188<
Delay Time (Sec)	250	125	50	20	5	2	1	0.32	0.16

A-5 Inverter Failure



If there is a short circuit in the output circuit when the power is supplied from the inverter, the UPS shuts down the inverter to shut off power to the loads. The fail LED  illuminates and the buzzer beeps continuously. The UPS does not switch on automatically after the short circuit condition disappears. The UPS must be re-started manually. Refer to Section 5.2.1, Start Up in Normal AC Mode.

A-6 Inverter/Internal Over temperature

The UPS switches to the bypass mode if the UPS experiences an internal over-temperature when the utility voltage is normal. The UPS switches back to the inverter mode when the over-temperature disappears. If an over temperature occurs when the utility voltage is outside the UPS design limits, the buzzer beeps continuously and the Fault LED  illuminates. The UPS shuts off the power to the loads.

A-7 Inverter Over

An Inverter Over condition means that the current and inverter output voltages are outside the design limits.

If the UPS inverter delivers an over-current and out-of-tolerance voltage to its outlets, the UPS is out of order. The UPS switches to the bypass mode if the utility voltage is normal. The Utility  LED, Bypass  LED, and Fault  LED illuminate.

If these two fault conditions occur when the utility voltage is outside the UPS design limits, the UPS shuts off the power to the loads and the Fault  LED illuminates.